

Material

Aluminium body, steel shell (flange), steel plunger pin and steel spring

Finish

Bright chrome or black powder coated

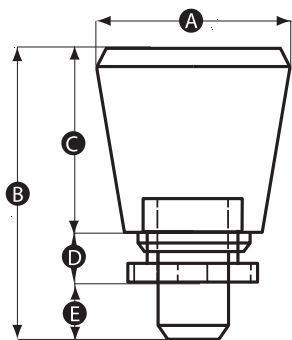

Cut out

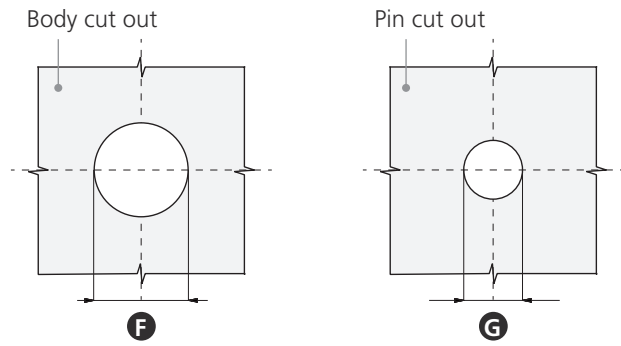

Part No.	A	B	C	D	E	F	G	Thread size	Plunger diameter (mm)	Body material	Rest position
15697T	14	20	13	2	5	7.1	4.8	M7	4.7	Aluminium	Yes
15698P	14	20	13	2	5	7.1	4.8	M7	4.7	Black powder coated aluminium	Yes
15222Q	17	27	17	2	8	9.1	6.3	M9	6.2	Aluminium	Yes
15223X	17	27	17	2	8	9.1	6.3	M9	6.2	Black powder coated aluminium	Yes

Assembly

- 1 Unscrew locking sleeve from plunger body.
- 2 Locking sleeve screws into plunger body through hole in plate.
- 3 Pin locates in frame panel hole.

